

瓦匠推荐  
更高标准。

永康市帅标工具有限公司  
YONGKANG SHUAIBIAO TOOLS CO.,LTD

地址Add:永康市西城街道烈桥智造科技小微园20号  
Yongkang City Xicheng Street Liqiao Zhizao technology small micro Park No. 20

电话Tel:  
0579-87277369 18757892776

传真Fax:  
0579-87293365

图片为本公司部分产品，款式及参数仅供参考，最终解释权归属本公司所有，如有更改，恕不另行通知！



# PROFESSIONAL LAYING TOOLS

专业铺贴工具制造商

# 01

MANUAL  
CUTTING SERIES 03-10

手动切割系列

# 02

TILING MACHINE  
SERIES 11-14

平铺机系列

# 03

SUCKER  
SERIES 15-18

吸盘系列

# 04

LEVELING TOOL  
SERIES 19-20

找平工具系列

# 05

SAW BLADE  
SERIES 21-22

锯片系列



# About US ▶

永康市帅标工具有限公司坐落在“五金之都”，现拥有生产厂房8000多平方米，员工80多人。帅标一直坚持稳健经营、持续创新、开放合作，在瓦工工具、电工工具等各领域取得了重大突破。帅标人一直秉承的“匠心精神”：精于工匠于心品于行，完全倾注于我们的产品当中。在不断完善以及延伸我们的产品体系，持续打造行业标杆，引领行业新风尚，我们的目标：瓦匠推荐 更高标准！

Yongkang Shuaibiao Tool Co., Ltd. is located in the "Hardware City", now has a production plant of more than 8000 square meters, more than 80 employees. Shuaiping has always adhered to sound management, continuous innovation, open cooperation and made major breakthroughs in various fields such as tile tools and electrical tools. The "spirit of ingenuity" that Shuai has always been adhering to: the craftsman, the heart of the product and the line, fully into our products. In the continuous improvement and extension of our product system, continue to create industry benchmark, leading the industry new fashion, our goal: bricklayers recommend a higher standard!

80<sup>+</sup>  
专业型员工

8000<sup>+</sup>  
m<sup>2</sup>  
现代化标准厂房





# 手动切割系列 - SERIES

# 手动瓷砖切割机 T-07

全新升级  
一切到底

激光辅助 / 拒绝偏差 / 强劲分段



切割长度 800-1200 mm  
大切割长度适用范围更广

切割厚度 15 mm  
切割能力更强



磁吸压块全程可视无遮挡



红外激光精准定位



收放自如稳定支架



精密轴承无需繁琐加油



钨钢合金刀轮切割锋利

尺寸 size	最大切割长度 Max cutting length	对应瓷砖对角 Correspondence Tile diagonal	最大切割厚度 Max cutting thickness	刀轮尺寸 Cutter wheel size	能否对角切割 Diagonal cutting
800	800	55X55CM	15	Φ22*Φ6*6	OK
1000	1000	70X70CM	15	Φ22*Φ6*6	OK
1200	1200	85X85CM	15	Φ22*Φ6*6	OK

名称 Name	型号 Model	尺寸 size	最大切割长度 Max cutting length	对应瓷砖对角 Correspondence Tile diagonal	最大切割厚度 Max cutting thickness	刀轮尺寸 Cutter wheel size	能否对角切割 Diagonal cutting
 手动瓷砖切割机 MANUAL TILE CUTTER	T-07A	1600	1600	110X110CM	15	Φ22*Φ6*6	OK
		1800	1800	125X125CM	15	Φ22*Φ6*6	OK

# 手动瓷砖工业级切割机

## C-10

**锋利刀头  
切割整齐**

轻松切割—推到底/拒绝偏差/精准切割



**切割长度** 1200-1800 mm  
大切割长度适用范围更广

**切割厚度** 15 mm  
切割能力更强

尺寸 size	最大切割长度 Max cutting length	对应瓷砖对角 Corresponding tile diagonal	最大切割厚度 Max cutting thickness	刀轮尺寸 Cutter wheel size	能否对角切割 Diagonal cutting
1200	1200	85X85CM	15	Φ22*Φ6*6	OK
1600	1600	110X110CM	15	Φ22*Φ6*6	OK
1800	1800	125X125CM	15	Φ22*Φ6*6	OK



采用绿光，光线超亮  
不刺眼，穿透力强



采用20CM宽全铝底板  
切割底盘更稳

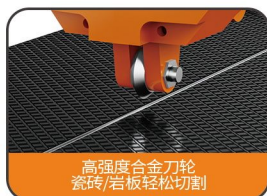

高强度合金刀轮  
瓷砖/岩板轻松切割



轻型顺滑承重轮  
占地小，轻便携带



磁吸式压脚  
切割空间更宽敞



EVA三层高端压垫  
避震/防滑/耐腐蚀

# 手动瓷砖切割机

## T-01



**切割长度** 600-800 mm  
大切割长度适用范围更广

**切割厚度** 15 mm  
切割能力更强

尺寸 size	最大切割长度 Max cutting length	对应瓷砖对角 Corresponding tile diagonal	最大切割厚度 Max cutting thickness	刀轮尺寸 Cutter wheel size	能否对角切割 Diagonal cutting
600	600	40X40CM	15	Φ22*Φ6*6	OK
800	800	55X55CM	15	Φ22*Φ6*6	OK

# 手动瓷砖切割机

## T-03

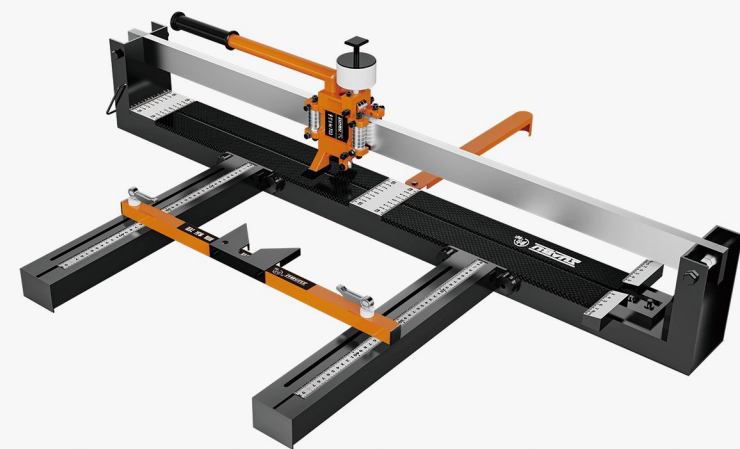

**切割长度** 800-1800 mm  
大切割长度适用范围更广

**切割厚度** 15 mm  
切割能力更强

高强度合金刀轮，锋利刀锋  
多种材质—机搞定  
各种瓷砖轻松切割  
激光定位设计，精准切割有保障

尺寸 size	最大切割长度 Max cutting length	对应瓷砖对角 Corresponding tile diagonal	最大切割厚度 Max cutting thickness	刀轮尺寸 Cutter wheel size	能否对角切割 Diagonal cutting
800	800	55X55CM	15	Φ22*Φ6*6	OK
1000	1000	70X70CM	15	Φ22*Φ6*6	OK
1200	1200	85X85CM	15	Φ22*Φ6*6	OK
1600	1600	110X110CM	15	Φ22*Φ6*6	OK
1800	1800	125X125CM	15	Φ22*Φ6*6	OK

名称 Name	型号 Model	尺寸 size	最大切割长度 Max cutting length	对应瓷砖对角 Correspondence Tile diagonal	最大切割厚度 Max cutting thickness	刀轮尺寸 Cutter wheel size	能否 对角切割 Diagonal cutting
 手动瓷砖切割机 MANUAL TILE CUTTER	T-05	800	600	55X55CM	15	Φ22*Φ6*6	OK
		1000	1000	70X70CM	15	Φ22*Φ6*6	OK

- 高强度合金刀轮, 锋利刀锋
- 多种材质一机搞定
- 各种瓷砖轻松切割
- 激光定位设计, 精准切割有保障



切割长度 **800-1200 mm**  
大切割长度适用范围更广

切割厚度 **15 mm**  
切割能力更强

尺寸 size	最大切割长度 Max cutting length	对应瓷砖对角 Correspondence Tile diagonal	最大切割厚度 Max cutting thickness	刀轮尺寸 Cutter wheel size	能否对角切割 Diagonal cutting
800	800	55X55CM	15	Φ22*Φ6*6	OK
1000	1000	70X70CM	15	Φ22*Φ6*6	OK
1200	1200	85X85CM	15	Φ22*Φ6*6	OK

## T-06 手动瓷砖切割机

## 手动瓷砖切割机 T-10

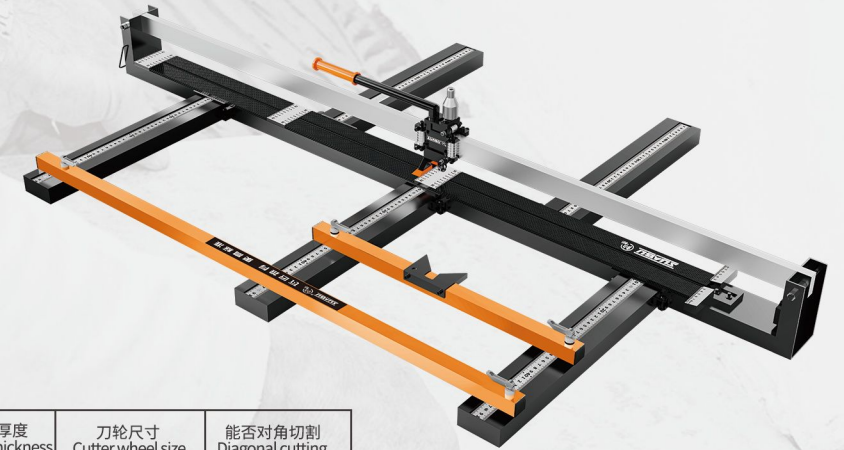

切割长度 **1600-1800 mm**  
大切割长度适用范围更广

切割厚度 **15 mm**  
切割能力更强

尺寸 size	最大切割长度 Max cutting length	对应瓷砖对角 Correspondence Tile diagonal	最大切割厚度 Max cutting thickness	刀轮尺寸 Cutter wheel size	能否对角切割 Diagonal cutting
1600	1600	110X110CM	15	Φ22*Φ6*6	OK
1800	1800	125X125CM	15	Φ22*Φ6*6	OK

## 手动瓷砖切割机 T-10A

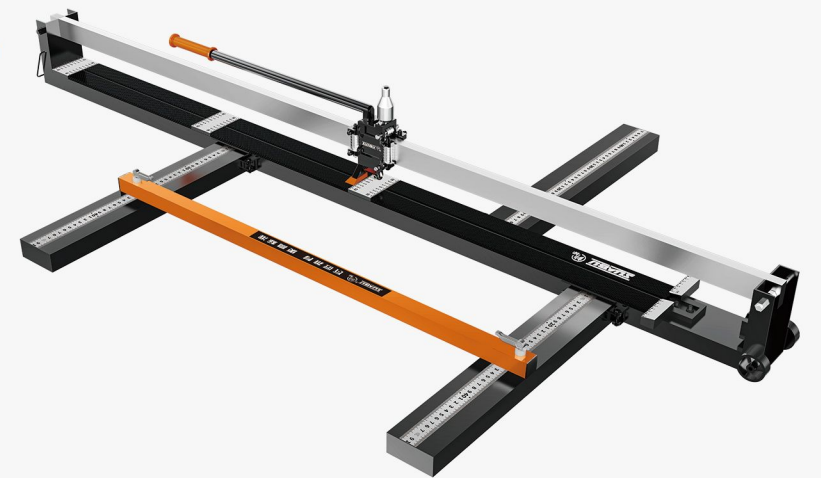

切割长度 **1600-1800 mm**  
大切割长度适用范围更广

切割厚度 **15 mm**  
切割能力更强

- 高强度合金刀轮, 锋利刀锋
- 多种材质一机搞定
- 各种瓷砖轻松切割
- 激光定位设计, 精准切割有保障

尺寸 size	最大切割长度 Max cutting length	对应瓷砖对角 Correspondence Tile diagonal	最大切割厚度 Max cutting thickness	刀轮尺寸 Cutter wheel size	能否对角切割 Diagonal cutting
1600	1600	110X110CM	15	Φ22*Φ6*6	OK
1800	1800	125X125CM	15	Φ22*Φ6*6	OK



名称 Name	型号 Model	尺寸 size	最大 切割长度 Max cutting length	对应 瓷砖对角 Correspondence Tile diagonal	最大 切割厚度 Max cutting thickness	刀轮尺寸 Cutter wheel size	能否 对角切割 Diagonal cutting
 手动瓷砖切割机 MANUAL TILE CUTTER	C-03	400	400	25X25CM	12	Φ22*Φ6*6	OK
		600	600	40X40CM	12	Φ22*Φ6*6	OK
		800	800	55X55CM	12	Φ22*Φ6*6	OK
		1000	1000	70X70CM	12	Φ22*Φ6*6	OK
 手动瓷砖切割机 MANUAL TILE CUTTER	C-05	600	600	40X40CM	12	Φ22*Φ6*6	OK
		800	800	55X55CM	12	Φ22*Φ6*6	OK
		1000	1000	70X70CM	12	Φ22*Φ6*6	OK
		1200	1200	85X85CM	12	Φ22*Φ6*6	OK
 手动瓷砖切割机 MANUAL TILE CUTTER	C-07	800	800	55X55CM	12	Φ22*Φ6*6	OK
		1000	1000	70X70CM	12	Φ22*Φ6*6	OK
		1200	1200	85X85CM	12	Φ22*Φ6*6	OK

- 专为岩板切割设计
- 高强度合金刀轮, 锋利刀锋
- 多种材质一机搞定  
各种瓷砖轻松切割
- 采用优质铝合金制造  
轻便实用, 导轨内置吸盘  
牢固吸附岩板

## 大板切割机 C-11



尺寸 size	最大切割长度 Max cutting length	最大切割厚度 Max cutting thickness	刀轮尺寸 Cutter wheel size	能否对角切割 Diagonal cutting
600	600	12	Φ22*Φ6*6	NO
800	800	12	Φ22*Φ6*6	NO
1000	1000	12	Φ22*Φ6*6	NO
1200	1200	12	Φ22*Φ6*6	NO

SUABU® 帥標



平铺机  
系列  
SERIES

# 锂电瓷砖平铺机 601-5

大容量锂电池  
持久续航

吸力强劲 / 一键吸附 / 续航持久

- 额定电压 21V 输出稳定更高效
- 电池容量 2.0Ah 大容量更持久
- 续航时间 2h 持久更耐用



锁定按钮吸附牢固更轻松



145MM

145MM大直径吸盘



辅助手柄设计握持更轻松



防滑手柄设计



无极变速开关，操作轻松

吸盘直径 diameter	电池容量 Battery capacity	电池电压 Battery voltage	充电电流 Charging current	续航时间 Charging time	垂直吸力 Vertical suction
145	2.0Ah	21V	1A	2.0H	50KG

# 锂电瓷砖平铺机 601-7

- 额定电压** 21V  
输出稳定更高效
- 电池容量** 2.0Ah  
大容量更持久
- 续航时间** 2h  
持久更耐用

**21V 锂电  
持久续航**



吸盘直径 diameter	电池容量 Battery capacity	电池电压 Battery voltage	充电电流 Charging current	续航时间 Charging time	垂直吸力 Vertical suction
160	2.0Ah	21V	1A	2.0H	80KG

# 锂电瓷砖平铺机 601-1

**吸盘直径 120mm**  
大直径吸附能力更强



- 加厚加大吸盘强吸不掉
- 超强动力, 功能强劲
- 轻松吸附多种材质物体
- 大容量锂电池持久续航

电池容量 Battery capacity	电池电压 Battery voltage	充电电流 Charging current	电池充电时间 Charging time	垂直吸力 Vertical suction
2.0Ah	8.4V	1A	2.0H	25KG

# 无刷锂电瓷砖平铺机 601-8

**吸盘直径 160mm**  
大直径吸附能力更强



- 无刷电机, 待机时间长, 更耐用
- 吸附快速提高工作效率
- 强劲吸附能力持久不漏气
- 防滑手柄耐磨更舒适
- 更大承重, 吸住不脱落

电池容量 Battery capacity	电池电压 Battery voltage	充电电流 Charging current	电池充电时间 Charging time	垂直吸力 Vertical suction
2.0Ah	21V	1A	2.0H	80KG

# 锂电瓷砖平铺机 601-3

**吸盘直径 130mm**  
大直径吸附能力更强



- 吸附快速提高工作效率
- 强劲吸附能力持久不漏气
- 防滑手柄耐磨更舒适
- 更大承重, 吸住不脱落

电池容量 Battery capacity	电池电压 Battery voltage	充电电流 Charging current	电池充电时间 Charging time	垂直吸力 Vertical suction
2.0Ah	16.8V	1A	2.0H	30KG

# 锂电瓷砖平铺机 601-9

**吸盘直径 160mm**  
大直径吸附能力更强



- 数显9个档位调速  
满足不同场景需求
- 吸附快速提高工作效率
- 强劲吸 附能力持久不漏气
- 防滑手柄耐磨更舒适  
更大承重, 吸住不脱落

电池容量 Battery capacity	电池电压 Battery voltage	充电电流 Charging current	电池充电时间 Charging time	垂直吸力 Vertical suction
2.0Ah	21V	1A	2.0H	80KG



SUABU® 帥标



吸盘系列  
S SERIES

# 锂电真空吸盘 7701

- 额定电压** 12V  
输出稳定更高效
- 电池容量** 1.5Ah  
大容量更持久
- 充电时间** 2h  
快速充电更省心

**全新升级  
吸力稳固**  
耐用度高 / 不易磨损 / 强力承重



一键吸附使用更轻松



大容量电池续航持久耐用



密封圈设计轻松吸附不漏气



各种材质表面轻松吸附



可以满足毛面吸附

吸盘材质 Sucker material	垂直吸力 Vertical suction	额定电压 Rated voltage	电池容量 Battery capacity	充电时间 Charging time	装箱数 Packing quantity	外箱尺寸 Carton size
丁晴橡胶/泡棉	180KG	12V	1.5AH	2H	8PCS	64X38X47 (CM)



## 锂电真空吸盘 7702

- 额定电压** 3.7V  
输出稳定更高效
- 电池容量** 3.0Ah  
大容量更持久
- 充电时间** 4h  
快速充电更省心

- 加厚加大吸盘强吸不掉
- 超强动力, 功能强劲
- 轻松吸附多种材质物体
- 大容量锂电池持久续航



吸盘材质 Material	吸盘直径 Diameter	垂直吸力 Vertical suction	装箱数 Packing quantity	外箱尺寸 Carton size
丁晴橡胶	200MM	200KG	10PCS	53.5X24X55

## 手动真空吸盘 7601



- 吸附快速提高工作效率
- 强劲吸附能力持久不漏气
- 防滑手柄耐磨更舒适
- 更大承重, 吸住不脱落

吸盘材质 Material	吸盘直径 Diameter	垂直吸力 Vertical suction	装箱数 Packing quantity	外箱尺寸 Carton size
丁晴橡胶	220MM	150KG	8PCS	67X28X64

## 手动真空吸盘 7602



- 吸附快速提高工作效率
- 强劲吸附能力持久不漏气
- 防滑手柄耐磨更舒适
- 更大承重, 吸住不脱落

吸盘材质 Material	吸盘直径 Diameter	垂直吸力 Vertical suction	装箱数 Packing quantity	外箱尺寸 Carton size
丁晴橡胶	205MM	150KG	20PCS	55X45X45

## 手动真空吸盘(压力表) 7603



- 吸附快速提高工作效率
- 强劲吸附能力持久不漏气
- 防滑手柄耐磨更舒适
- 更大承重, 吸住不脱落

吸盘材质 Material	吸盘直径 Diameter	垂直吸力 Vertical suction	装箱数 Packing quantity	外箱尺寸 Carton size
丁晴橡胶	200MM	150KG	10PCS	55X52X30



# 找平工具系列 SERIES

## 高精度水平尺

- 高精度, 找平更精准
- 高强度铝合金制造
- 防锈耐磨, 抗压性强
- 高清刻度尺显示, 工作更便捷



产品型号 Model	产品长度 Length	产品重量 Weight
9060	60CM	0.4KG
9100	100CM	0.62KG
9120	120CM	0.72KG

## 墙砖抬高器 TJ01

- 升级加厚, 承重能力强
- 告别滑位, 经久耐用
- 手柄可轻松握持, 调节更轻松
- 底座牢固, 稳定不晃动



调节高度 Adjust height	单台承重 Mx load
1-10CM	30KG

## 墙砖抬高器 TJ02

- 升级加厚, 承重能力强
- 告别滑位, 经久耐用
- 手柄可轻松握持, 调节更轻松
- 底座牢固, 稳定不晃动

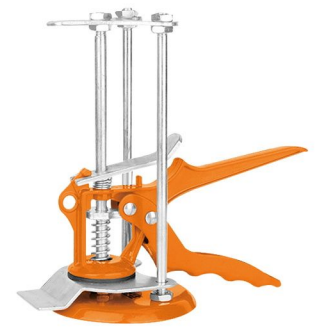

调节高度 Adjust height	单台承重 Mx load
1-10CM	50KG

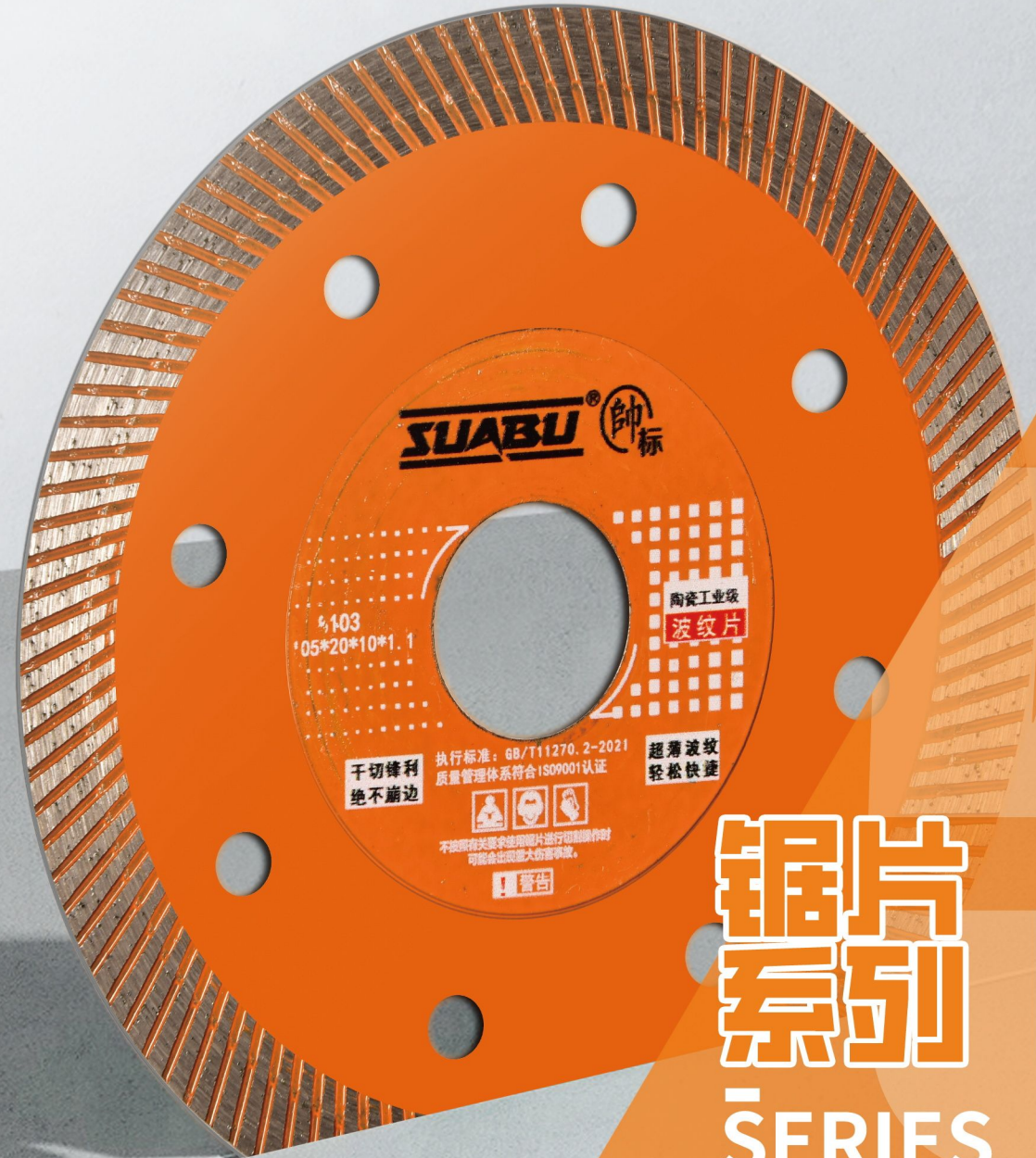

**锯片  
系列  
-  
SERIES**

**陶瓷专用级波纹片  
8101S**

锯片尺寸  
Size  
105\*20\*10\*1.1



**陶瓷专业级波纹片  
8102G**

锯片尺寸  
Size  
105\*20\*10\*1.1



**陶瓷工业级波纹片  
8103G**

锯片尺寸  
Size  
105\*20\*10\*1.1



**岩板专业级钎焊片  
8201S**

锯片尺寸  
Size  
100\*20\*10\*0.8



**岩板专业级钎焊片  
8203S**

锯片尺寸  
Size  
110\*20\*15\*0.8



**专业级石材切割片  
8301G/S**

锯片尺寸  
Size  
110\*20\*15\*1.0



**岩板工业级钎焊片  
8202G**

锯片尺寸  
Size  
100\*20\*10\*0.8



**岩板工业级钎焊片  
8204G**

锯片尺寸  
Size  
110\*20\*15\*0.8



**工业级石材切割片  
8302G**

锯片尺寸  
Size  
110\*20\*15\*1.0



**岩板平磨片  
8303**

锯片尺寸  
Size  
100\*20\*30\*1.0



**更多产品  
敬请期待.....**